

ARMADA™

Surgical Technique



CONTENTS

Preface	1
Armada [™] Surgical Technique	2
Equipment Requirements	2
Patient Positioning and O.R. Setup	2
Pedicle Preparation	3
Screw Insertion	4
Iliac Preparation	6
Iliac Screw Insertion	7
Offset Connectors	8
Rod Contouring	9
Rod Insertion	10
Rod Reduction	11
Rod Rotation	16
Vertebral Body Derotation	17
In-Situ Rod Bending	20
Compression and Distraction	21
Final Tightening	22
Transverse Connector	23
Implant Removal	26
Armada System	28
Catalog	46

PREFACE

Fellow Colleagues:

The surgical management of spinal deformities has evolved considerably since the use of distractive techniques applied to hook-and-rod constructs. Current posterior pedicle-based fixation has enabled us to achieve improved three-dimensional correction and enhanced clinical outcomes. With the development of advanced instrumentation systems and surgical techniques, we are able to treat the most difficult pathologies.

Since the onset of this project, our goal was to develop a comprehensive posterior fixation system consisting of a broad array of advanced implants and instrumentation capable of addressing complex spinal deformities with efficiency and precision. The resulting Armada[™] spinal system represents the culmination of extensive clinical evaluation and refinement, and offers several compelling features:

- **Double Lead Threads:** Pedicle screws incorporate a double lead thread form for efficient screw insertion.
- **Provisional Locking Screw:** Polyaxial screws which may be locked into a fixed position, allowing for derotation maneuvers or parallel compression and distraction.
- **Helical Flange Locking Mechanism:** Patented design reduces the propensity to cross-thread and minimizes head splay, providing predictable results throughout the procedure.
- **Elegant Instrumentation:** Ergonomic and elegantly designed instrumentation that affords a wide range of corrective techniques, including a versatile, multi-use reduction and derotation device.

We feel confident that you will find Armada to be a comprehensive and highly advanced spinal system for the management of complex spinal pathologies.

Cordially,

Jason E. Lowenstein, M.D.
Orthopaedic Surgeon
SpineAustin
Austin, TX

Vedat Deviren, M.D.
Orthopaedic Surgeon
UCSF Medical Center
San Francisco, CA

Scott Shoemaker, M.D.
Pediatric Orthopaedic Surgeon
San Diego, CA

Ramin Bagheri, M.D.
Orthopaedic Surgeon
San Diego Center for Spinal Disorders
La Jolla, CA



ARMADA[™] SURGICAL TECHNIQUE

ARMADA[™] SURGICAL TECHNIQUE

EQUIPMENT REQUIREMENTS

- Armada[™] 5.5mm Degenerative Instrument Tray One
- Armada 5.5mm Degenerative Instrument Tray Two
- Armada 5.5mm Ti Degenerative Implant Tray
- C-Arm Fluoroscope
- Radiolucent Surgical Table
- NeuroVision[®] M5[™]

Optional:

- Armada 5.5mm Ti Long Construct Implant Tray
- Armada 5.5mm Ti Reduction Screw Implant Tray
- Armada 5.5mm Ti Open Iliac Implant Tray
- Armada 5.5mm Deformity Instrument Tray One
- Armada 5.5mm Deformity Instrument Tray Two
- Armada 5.5mm Ti Deformity Implant Tray One
- Armada 5.5mm Ti Deformity Implant Tray Two
- Armada Rod Cutter Tray

For important labeling information, please reference the Instructions for Use (IFU).

PATIENT POSITIONING AND O.R. SETUP

Place the patient on the operating table in a prone position. Prepare and drape in a conventional manner. Fluoroscope should have easy access to the surgical field for both A/P and lateral views. Fluoroscopic monitors and NeuroVision unit should be placed in clear view (Fig. 1).



(Fig. 1)



**STEP 1:
PEDICLE PREPARATION**

Locate the desired entry point into the pedicle and perforate the cortex with an Awl or high-speed burr. Create a pilot hole by passing the Gearshift Probe through the pedicle and into the vertebral body (Fig. 2). Take care to ensure the instrument(s) do not breach the cortical wall of the pedicle, as the pilot hole will ultimately determine the final position of the screw. Inspect the pilot hole for perforations by inserting a Ball Tip Pedicle Probe and palpating the pedicle wall on all sides. Pedicle markers may also be placed into the pilot holes, followed by A/P and lateral imaging to verify proper positioning.

Armada[™] screws are self-tapping and may be inserted at this point. If tapping is preferred, tap through the pedicle into the vertebral body, using the markings on the shaft and fluoroscopy to determine depth (Fig. 3). Prior to screw insertion, inspect the pilot holes again for perforations, using the Ball Tip Pedicle Probe (Fig. 4).



(Fig. 2)

(Fig. 3)

(Fig. 4)



ARMADA[™] SURGICAL TECHNIQUE

STEP 2:
SCREW INSERTION

With the pedicles prepared, determine the appropriate screw length. Select the Screwdriver corresponding to the pedicle screw to be implanted, and insert into the head of the screw (Fig. 5). Ensure the tip of the Screwdriver is fully inserted into the shaft of the screw and secure by fully threading the outer sleeve into the screw head (Fig. 6).

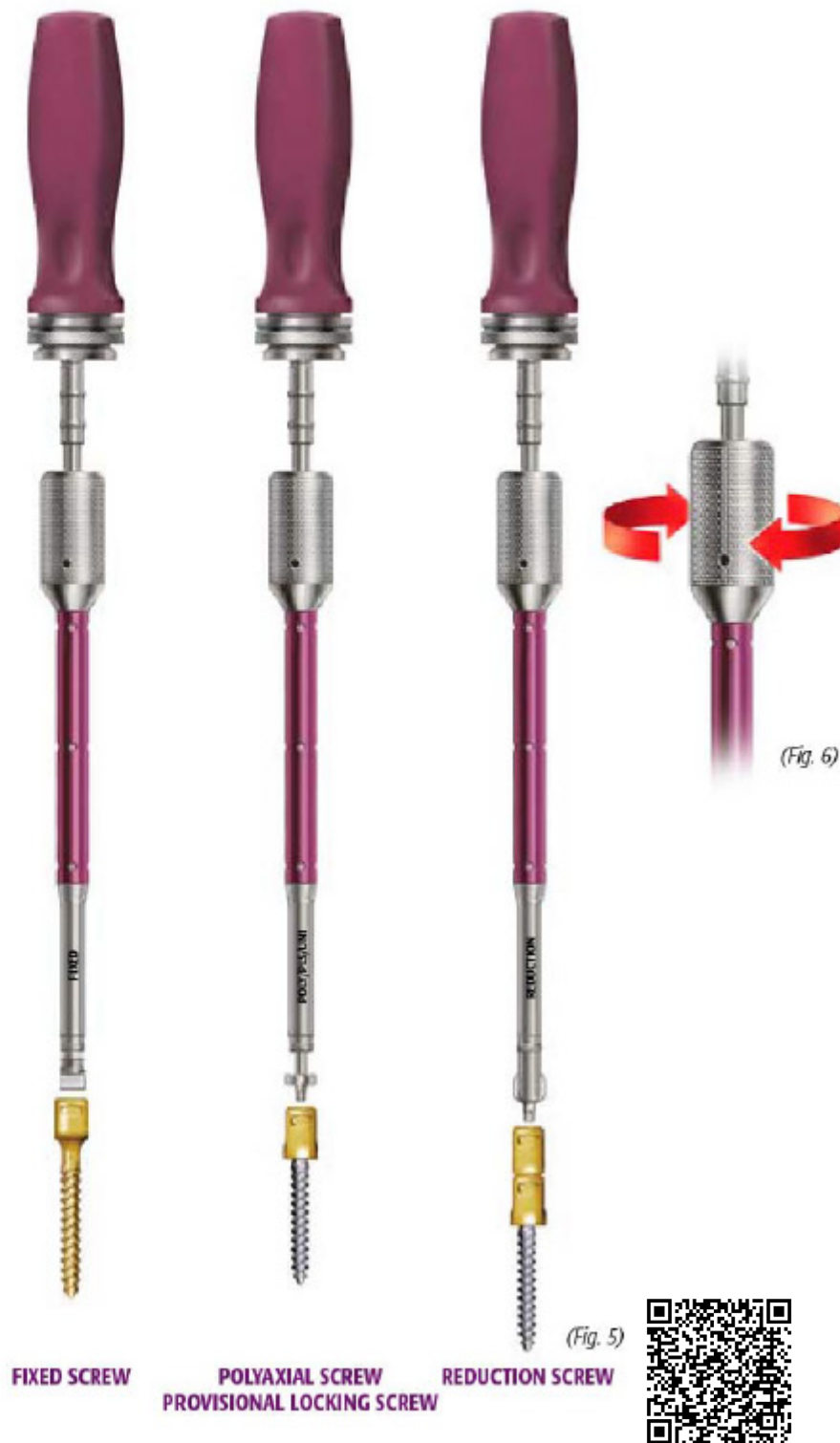

ARMADA[™] SURGICAL TECHNIQUE

STEP 2:
SCREW INSERTION (CONT.)

Introduce the screw into the pilot hole and advance until the desired depth is reached (Fig. 7). The Screwdriver's sleeve is designed to rotate freely, allowing the instrument to be firmly grasped throughout insertion without early release from the screw. To release the Screwdriver, turn the knurled section counterclockwise until the outer sleeve is fully unthreaded from the tulip and remove from the screw. For polyaxial screws, ensure the head of the screw is free from impedance and retains its full polyaxial motion. If additional adjustment to screw depth is required, the Screw Adjuster may be used.



ARMADA[™] SURGICAL TECHNIQUE

STEP 3:
ILIAC PREPARATION

If iliac screw fixation is desired, prepare the ilium using a burr or rongeur. Determine the desired trajectory of the iliac screw and advance the Iliac Gearshift Probe down between the iliac tables, aiming for the thick bone just above the greater sciatic notch (Fig. 8). Inspect the pilot hole for cortical wall violations using a Ball Tip Probe. Fluoroscopy can be utilized to further assess and adjust screw placement. Prior to iliac screw insertion, tap the pilot hole with a Single Lead Tap using the markings on the shaft and fluoroscopy to determine depth (Fig. 9). Inspect the pilot holes again for perforations using the Ball Tip Probe.

CAUTION:
Iliac screws have a single lead thread on the shaft and must be used with Single Lead Taps to ensure proper purchase in bone.

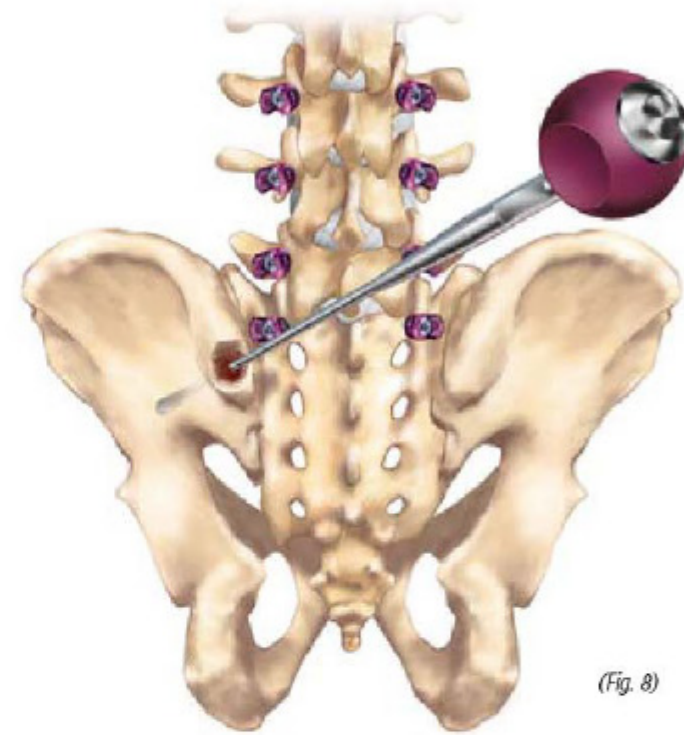

(Fig. 8)

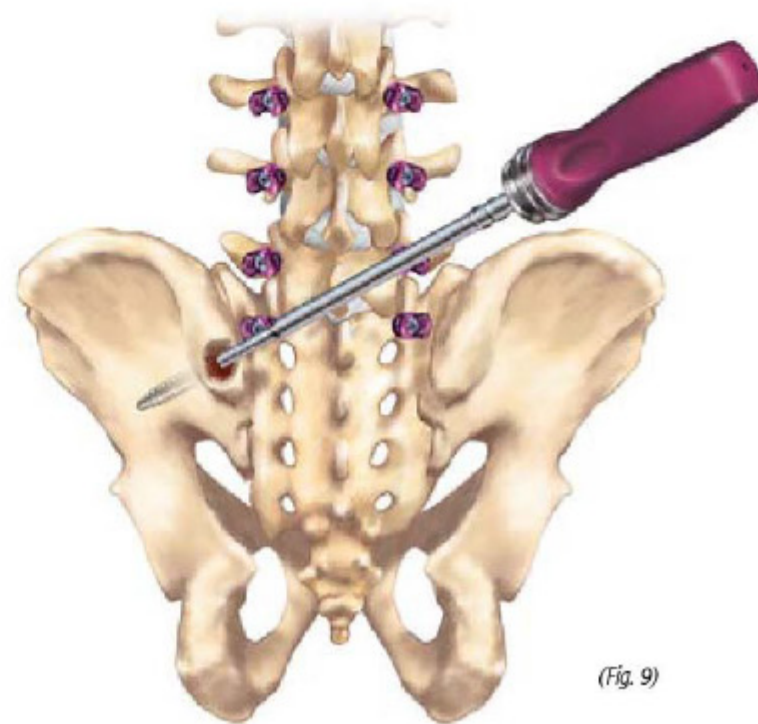

(Fig. 9)



ARMADA[™] SURGICAL TECHNIQUE

STEP 4:
ILIAC SCREW INSERTION

With the ilium prepared, select the appropriate screw length and insert the Screwdriver into the head of the screw (Fig. 10). Ensure the tip of the Screwdriver is fully inserted into the shaft of the screw and secure by fully threading the outer sleeve into the screw head (Fig. 11). Insert the iliac screw into the pilot hole and advance until the desired depth is reached (Fig. 12). To release the Screwdriver, turn the knurled section counterclockwise until the outer sleeve is fully unthreaded from the tulip and remove from the screw. If additional adjustment to screw depth is required, the Screw Adjuster may be used.

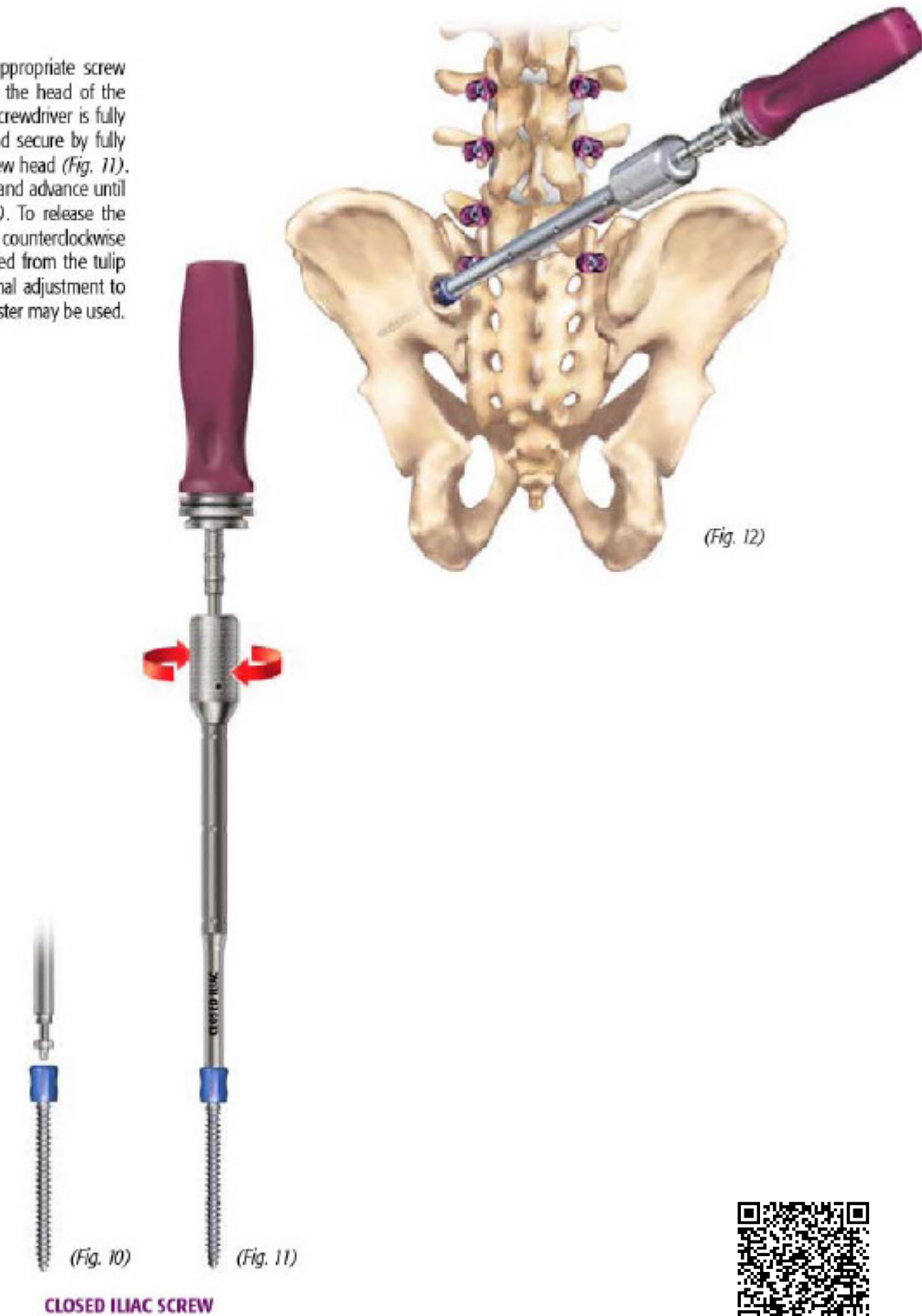

(Fig. 12)

(Fig. 10)

(Fig. 11)

CLOSED ILIAC SCREW



ARMADA™ SURGICAL TECHNIQUE

**STEP 5:
OFFSET CONNECTORS**

An offset connector may be used to connect the iliac screw to the rod. Determine the offset length required and insert the shaft of the connector into the rod slot of the iliac screw (Fig. 13). A Rod Holder may be used to assist in placement. To hold the offset connector in position, insert the lock screw into the tulip of the iliac screw using the Lock Screw Starter and provisionally tighten.

Closed iliac screws and closed offset connectors utilize the closed tulip lock screw. Open iliac screws and open offset connectors utilize the standard lock screws.

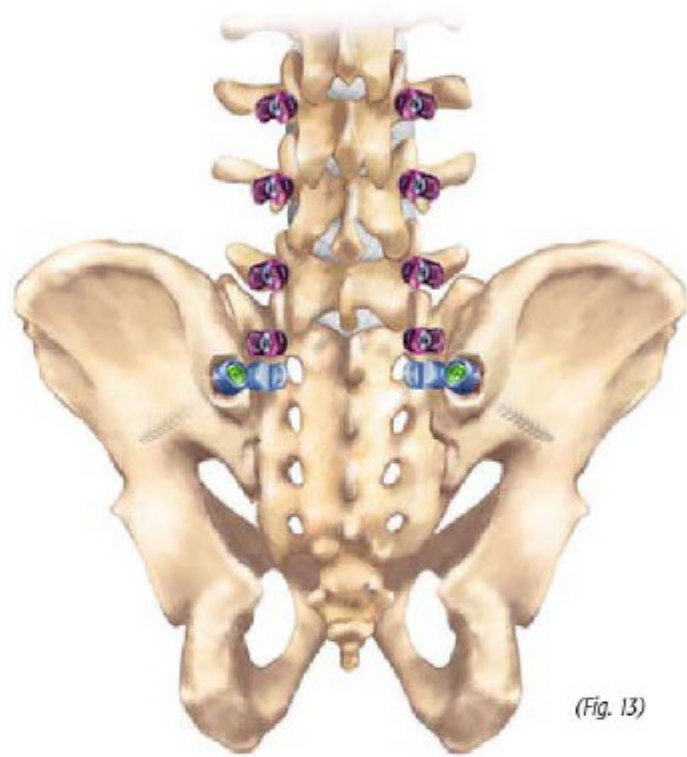

(Fig. 13)



ARMADA™ SURGICAL TECHNIQUE

**STEP 6:
ROD CONTOURING**

Once all screws are in position, use a rod template to measure the length. Contour the rod to the desired curve using the French Bender (Fig. 14). To achieve large radius bends, the Rod Benders may be utilized (Fig. 15).

The 300mm and 500mm rods have longitudinal lines to aid in aligning the curve along the same plane down the length of the rod.



(Fig. 14)



(Fig. 15)



ARMADA[™] SURGICAL TECHNIQUE

**STEP 7:
ROD INSERTION**

Once the rod has been cut to length and contoured, insert the rod into either the most cephalad or caudal end of the construct. Secure the rod in position by threading lock screws into the tulips with the Lock Screw Starter. The Rod Holder may be used to assist in placing the rod (Fig. 16).



During rod insertion, NeuroVision[®] may be set to Free Run mode.



(Fig. 16)



ARMADA[™] SURGICAL TECHNIQUE

**STEP 8:
ROD REDUCTION**

Reduction Tower

The Reduction Tower should be used whenever a large amount of reduction is required. Prior to engaging the tulip, ensure that the center shaft is fully unthreaded in the counterclockwise direction and that the reducer arm is open by sliding the thumbpiece downward (Fig. 17). Place the Reduction Tower over the rod and around the screw head so the step on the inside of the tip rests on the top of the screw head and the oval engagement features are aligned. Secure the Reduction Tower to the screw by closing the handle to the shaft. Complete closure is verified when the thumbpiece clicks into its locked position (Fig. 18).



(Fig. 17)



(Fig. 18)



ARMADA[™] SURGICAL TECHNIQUE

STEP 8:
ROD REDUCTION (CONT.)

Reduction Tower (Cont.)

It is important to verify the Reduction Tower is fully engaged with the screw prior to use; failure to fully engage the Reduction Tower may result in disengagement from the screw during reduction. Attach the Reduction Tower T-Handle to the hex end of the shaft and slowly reduce the rod by turning the T-Handle clockwise until the rod is fully seated in the tulip (Fig. 19). Insert a lock screw through the T-Handle with a Lock Screw Starter to hold the rod in position. To remove the Reduction Tower from the screw, remove the Lock Screw Starter and turn the T-Handle counterclockwise until the reduction shaft has cleared the top of the tulip. Slide the thumbpiece downward to open the reducer arm and lift up to remove from the screw.

If performing rod reduction with multiple Reduction Towers in close proximity, attach a Quick Connect Straight Handle or T-Handle to the Provisional Locking Tool and engage over the hex end of the shaft to minimize interference with adjacent reducers.



ARMADA[™] SURGICAL TECHNIQUE

STEP 8:
ROD REDUCTION (CONT.)

Reduction Screw

When using reduction screws, slide the Reduction Counter-Torque over the screw head until the distal slot sits flush on the rod. Using the Lock Screw Starter, reduce the rod by threading a lock screw down the extended tabs. Be sure to apply downward force on the counter-torque so the slot remains fully seated on the rod (Fig. 20). The rod is fully reduced when the top of the lock screw is below the recessed ridge at the base of the extended tab. With the rod fully reduced and the counter-torque seated flush on the rod, slide the Reduction Screw Break-off Tool over the medial tab and rock in a lateral direction until it breaks free from the screw head (Fig. 21). Repeat this process on the lateral side. To expel the tabs from the Break-off Tool, slide the thumbpiece distally.

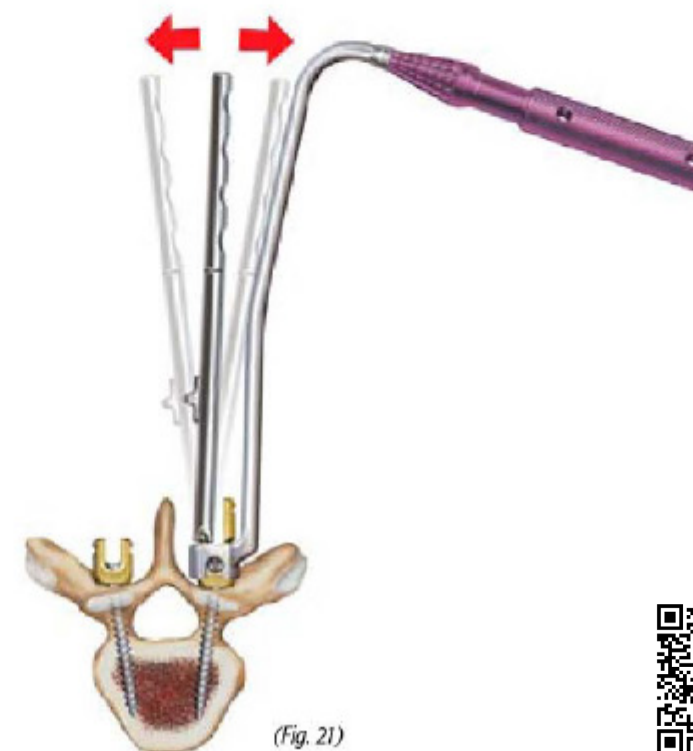

ARMADA[™] SURGICAL TECHNIQUE

ARMADA[™] SURGICAL TECHNIQUE

**STEP 8:
ROD REDUCTION (CONT.)**

Rocker

When only a small amount of reduction is required, the Rocker may be used to seat the rod. Grasp the screw head with the Rocker engaged in the circular center of the oval feature on both sides of the screw head. Deflect the Rocker downward until the screw is levered up and the rod is fully seated in the screw head (Fig. 22). Insert a lock screw using the Lock Screw Starter and release the instrument from the screw (Fig. 23).



**STEP 8:
ROD REDUCTION (CONT.)**

Kerrison Persuader

To reduce with the Kerrison Persuader, align the handle perpendicular to the rod and slide the distal tip over the screw head (Fig. 24). Slowly compress the handle to reduce the rod into the base of the tulip. Insert a lock screw using the Lock Screw Starter and release the instrument (Fig. 25).

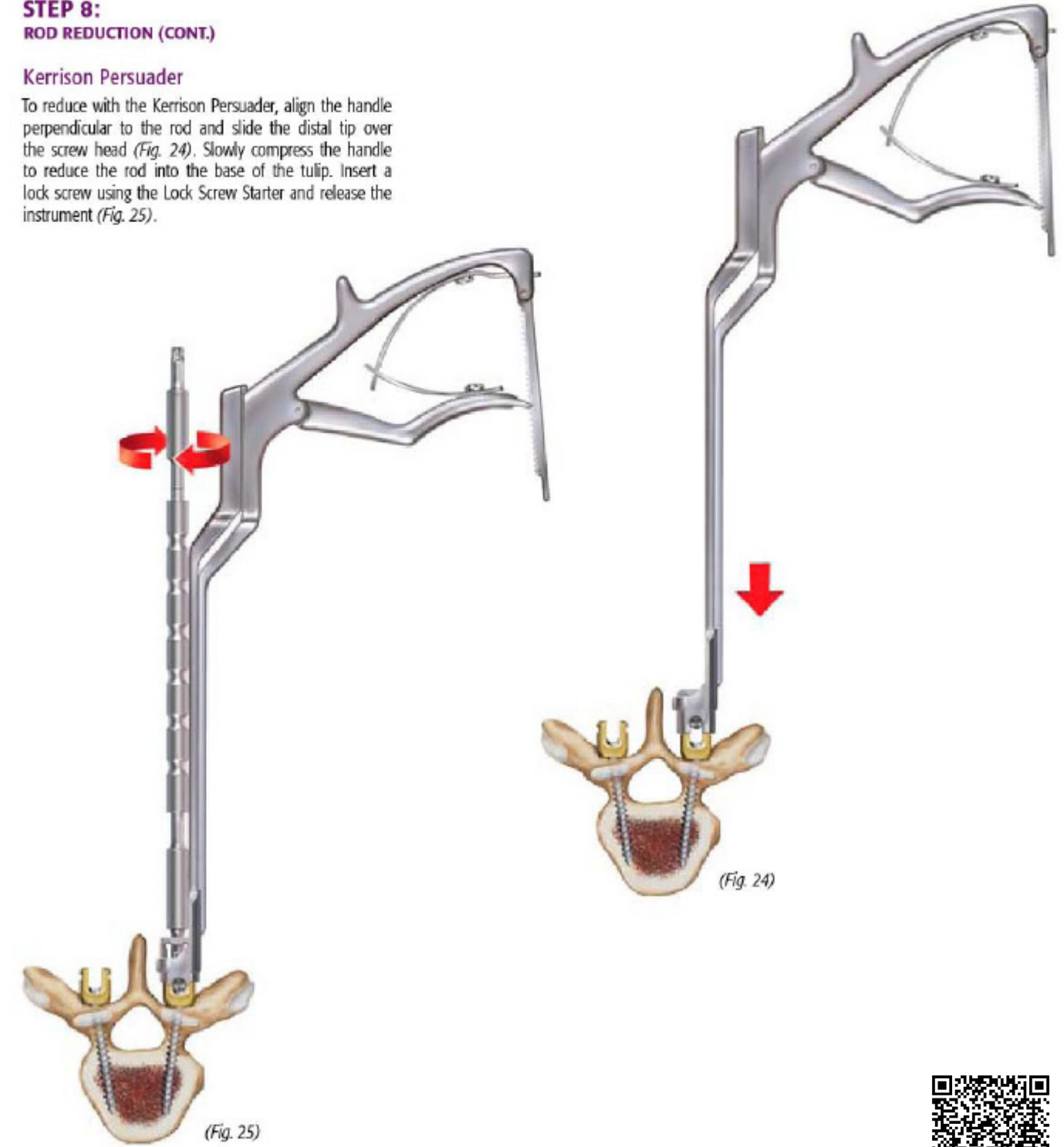

ARMADA[™] SURGICAL TECHNIQUE

**STEP 9:
ROD ROTATION**

With the lock screws provisionally tightened, rod rotation may be performed using the Rod Gripper. Ensure the tips of the Rod Gripper are open by depressing the button in the center of the ratchet (Fig. 26). Place the Rod Gripper over the rod and compress the handle until rigidly fixed to the rod. Perform rod rotation using two Rod Grippers to achieve the desired coronal and sagittal profiles (Fig. 27). After the rod has been rotated into its final position, tighten the lock screws using the Lock Screw Starter. To release the Rod Gripper from the rod, depress the button in the center of the ratchet.

The 300mm and 500mm rods have a hex end; a Rod Rotation Wrench may be used for rod rotation. Place the Rod Rotation Wrench over the hex end of the rod and rotate to achieve the desired amount of rod rotation (Fig. 27a).

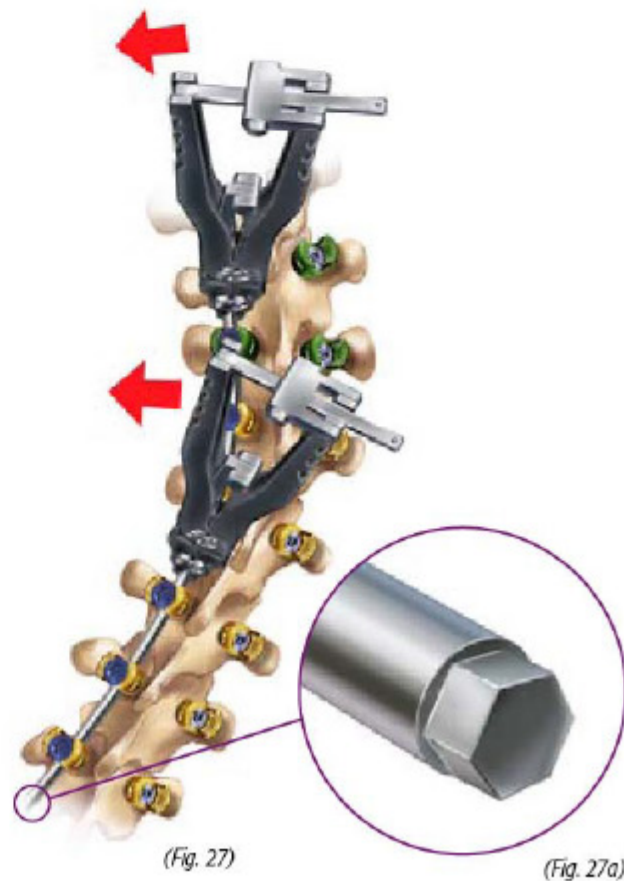
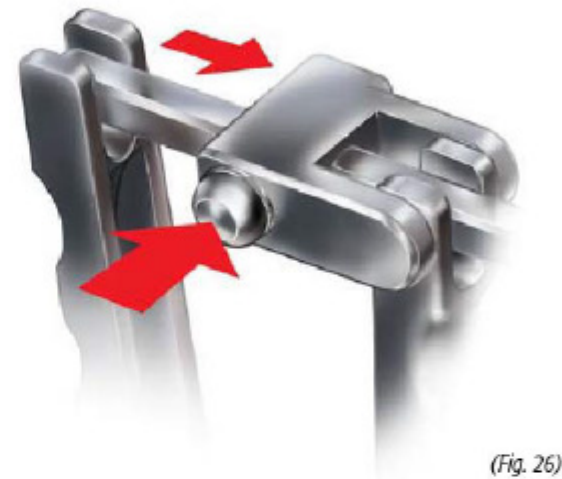

ARMADA[™] SURGICAL TECHNIQUE

**STEP 10:
VERTEBRAL BODY DEROTATION**

Vertebral body derotation may be performed using fixed or provisional locking screws (PLS). To apply rotational forces to fixed screws, slide the Lock Screw Guide/Derotation Tower over the screw head and move laterally to rotate the vertebral body in the axial plane (Fig. 28).

Prior to applying rotational forces to the PLS, the screw must be locked into a fixed position using the Reduction Tower. The Reduction Tower must be rigidly engaged to the screw head with the rod fully reduced (Fig. 29a). Slide the Reduction Tower Counter-Torque into the slots on the cranio/caudad sides of the instrument. Attach the Provisional Locking Tool to the Torque T-Handle, and engage over the hex end of the Reduction Tower (Fig. 29).

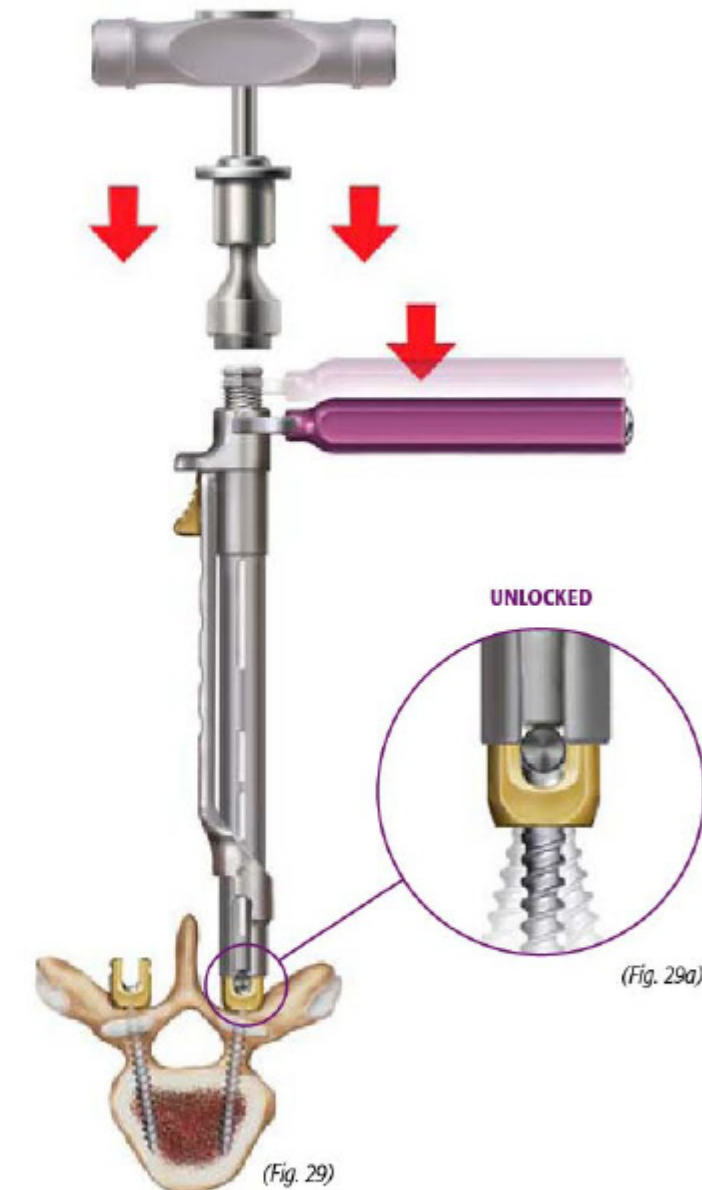

ARMADA™ SURGICAL TECHNIQUE

STEP 10:
VERTEBRAL BODY DEROTATION (CONT.)

To lock the PLS, rotate the Torque T-Handle clockwise until the breakaway torque is reached (Figs. 30, 30a). Once the PLS has been locked into a fixed position, rotate the Torque T-Handle counterclockwise to release the downward force on the rod.



ARMADA™ SURGICAL TECHNIQUE

STEP 10:
VERTEBRAL BODY DEROTATION (CONT.)

To lock the PLS, rotate the Torque T-Handle clockwise until the breakaway torque is reached (Figs. 30, 30a). Once the PLS has been locked into a fixed position, rotate the Torque T-Handle counterclockwise to release the downward force on the rod.

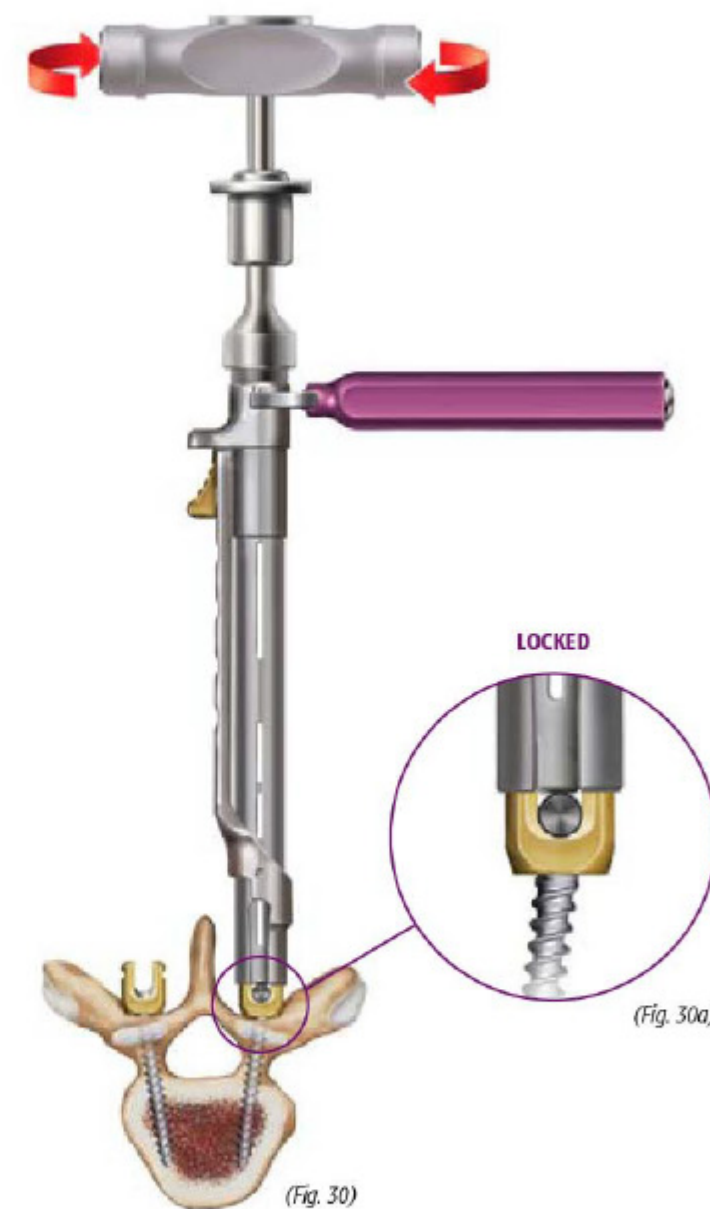

STEP 10:
VERTEBRAL BODY DEROTATION (CONT.)

With the PLS locked in a fixed position and both the Torque T-Handle and counter-torque removed, leverage the Reduction Tower laterally to rotate the vertebral body in the axial plane (Fig. 31). Once the desired amount of correction is achieved, insert the lock screw with the Lock Screw Starter and provisionally tighten to hold the rod in position. To remove the Reduction Tower from the PLS, reattach the Reduction Tower T-Handle and turn in a counterclockwise direction until the reduction shaft has cleared the top of the tulip. Slide the thumbpiece downward to open the reducer arm and lift up to remove from the screw.



STEP 10:
VERTEBRAL BODY DEROTATION (CONT.)

With the PLS locked in a fixed position and both the Torque T-Handle and counter-torque removed, leverage the Reduction Tower laterally to rotate the vertebral body in the axial plane (Fig. 31). Once the desired amount of correction is achieved, insert the lock screw with the Lock Screw Starter and provisionally tighten to hold the rod in position. To remove the Reduction Tower from the PLS, reattach the Reduction Tower T-Handle and turn in a counterclockwise direction until the reduction shaft has cleared the top of the tulip. Slide the thumbpiece downward to open the reducer arm and lift up to remove from the screw.



ARMADA[™] SURGICAL TECHNIQUE

STEP 11:
IN-SITU ROD BENDING

In-situ rod benders may be used for fine adjustments in the coronal and sagittal planes. Slide the tips of the In-Situ Sagittal Benders under the rod so that the rod sits flush within the rod slot at the location of desired kyphosis or lordosis. Compress the sagittal benders toward each other to achieve lordosis, or away from each other to produce kyphosis (Fig. 32). To adjust the coronal plane, slide the right and left In-Situ Coronal Benders over the rod until the slots sit flush. Compress the arms of the coronal benders toward each other using the ridges at the 90° bends for leverage (Fig. 33).

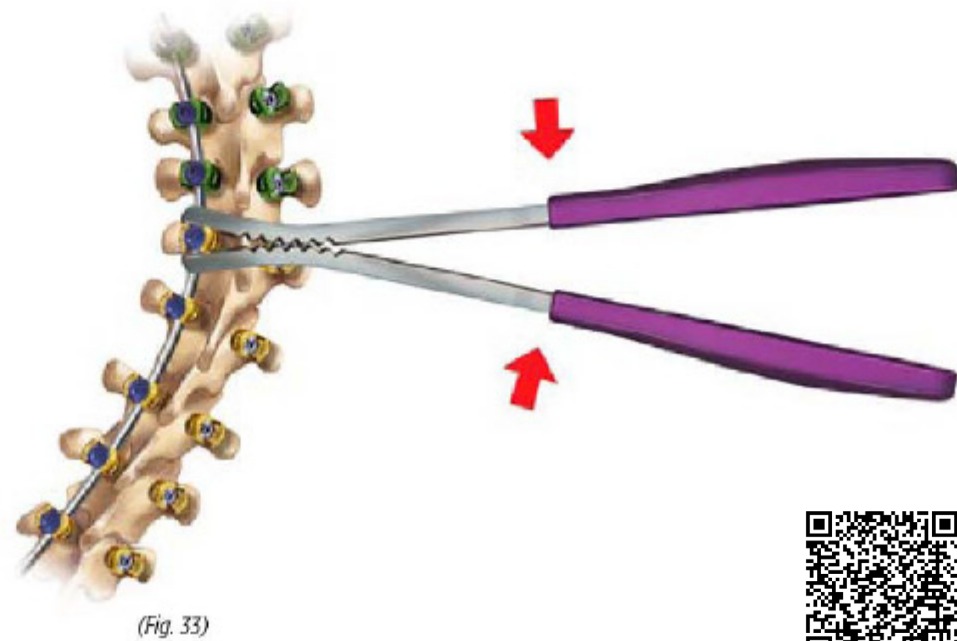
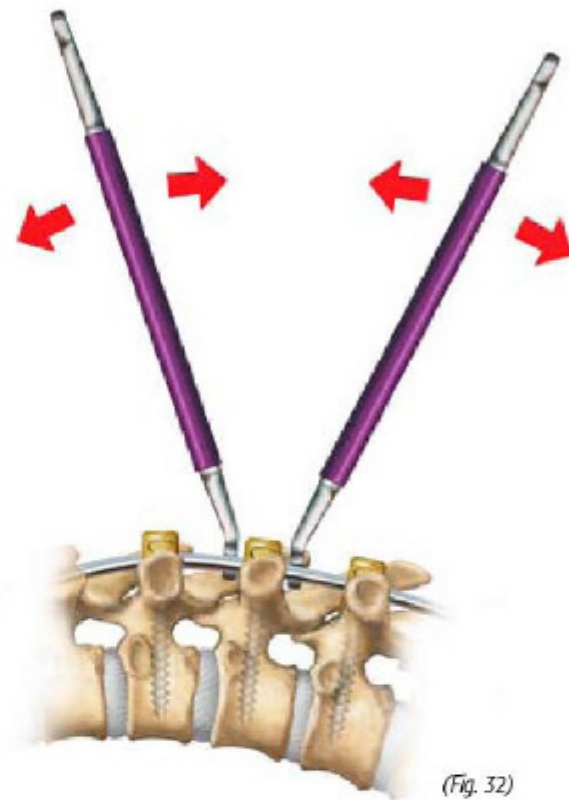

ARMADA[™] SURGICAL TECHNIQUE

STEP 12:
COMPRESSION AND DISTRACTION

If compression or distraction is desired, provisionally tighten the lock screw on one side of the motion segment, leaving the other lock screw loose to allow movement along the rod. Place the Compressor (Fig. 34) or Distractor (Fig. 35) over the rod and against the head of both screws. With the instrument properly engaged, deliver the desired level of compression or distraction and provisionally tighten the second lock screw to hold the construct in position prior to final tightening.



ARMADA[™] SURGICAL TECHNIQUE

STEP 13:
FINAL TIGHTENING

Place the Counter-Torque over the screw head until the slots at the distal end of the instrument are completely seated over the rod. With the Torque T-Handle engaged, insert the Lock Screwdriver through the Counter-Torque until it is securely seated into the lock screw (Fig. 36). Deliver final tightening and repeat on the remaining screws. The Closed Iliac Counter-Torque should be used to final tighten the closed iliac screws and closed offset connectors. The Open Offset Connector Counter-Torque should be used to final tighten the open offset connectors.



ARMADA[™] SURGICAL TECHNIQUE

STEP 14:
TRANSVERSE CONNECTOR

Fixed and adjustable transverse connectors are available in the Armada[™] system to provide torsional stability to the construct. Determine the appropriate length connector by measuring the distance between the rods using the Cross Connector Measurement Guide (Fig. 37).

Fixed Cross Connectors

When using fixed cross connectors, the Fixed Cross Connector Benders may be utilized to adjust the central arch (Fig. 38) or the orientation of the rod slots (Fig. 39). After placing the fixed cross connector into the Fixed Cross Connector Benders, slide the thumbpiece toward the connector to secure it in position. Compress the benders toward each other to achieve the desired bend. Once the fixed cross connector has been shaped, place the connector over both rods. Use the Fixed Cross Connector Driver to rotate the cam above each rod 180° into the final locked position (Fig. 40).

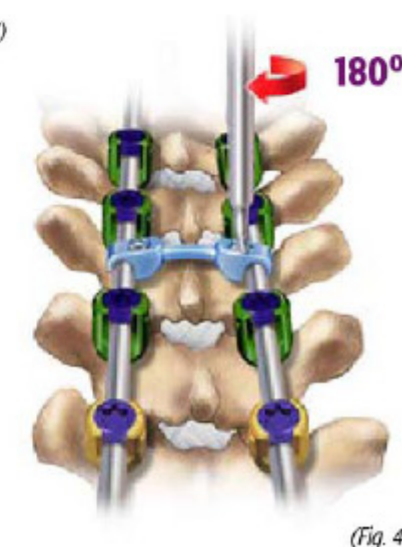
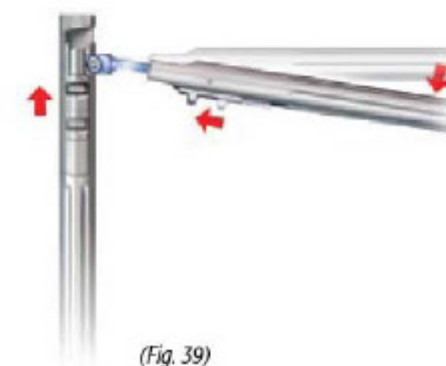
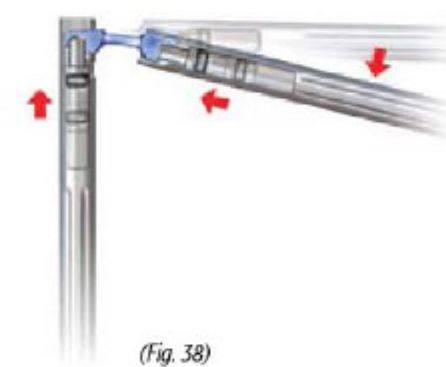

ARMADA[™] SURGICAL TECHNIQUE

ARMADA[™] SURGICAL TECHNIQUE

STEP 14:
TRANSVERSE CONNECTOR (CONT.)

Adjustable Cross Connector

Place the adjustable cross connector across both rods and press downward to securely engage the rod. Connect the Cross Connector Torque T-Handle onto the Adjustable Cross Connector Driver and tighten the nut on both sides of the adjustable cross connector until the breakaway torque is reached (Fig. 41). Once both sides of the adjustable cross connector are final tightened, proceed with final tightening the center lock nut (Fig. 42).



FINAL CONSTRUCT



ARMADA[™] SURGICAL TECHNIQUE

IMPLANT REMOVAL

Step 1: Cross Connector Removal

Connect the Cross Connector Torque T-Handle to the Adjustable Cross Connector Driver, and loosen the nut at the center of the cross connector by turning the handle counterclockwise. Once the center nut has been loosened, repeat on both sides. Using the Adjustable Cross Connector Holder, grasp the cross connector and lift up to remove. To remove the fixed cross connector, insert the Fixed Cross Connector Driver into the cam above each rod and rotate counterclockwise 180°. Once both cams have been unlocked, grasp the cross connector with the Fixed Cross Connector Holder and lift up to remove.

Step 2: Lock Screw Removal

Place the Counter-Torque over the screw head until the slots at the distal end of the instrument are completely seated over the rod. With a Quick Connect T-Handle engaged to the Lock Screwdriver, insert the instrument through the Counter-Torque until it is securely seated in the lock screw. Turn counterclockwise to loosen the lock screw, but do not fully unthread from the screw head. Repeat on the remaining screws. Once all lock screws have been loosened, remove the lock screw with a Lock Screw Starter, ensuring the lock screw is retained on the Lock Screw Starter.

Step 3: Rod and/or Rod-to-Rod Connector Removal

Once all the lock screws have been removed from the tulips, grasp the rod with a Rod Holder and lift up to remove from the screw heads. To remove a rod-to-rod connector, attach a Quick Connect T-Handle to the Lock Screwdriver and insert into the lock screw. Rotate counterclockwise until loose. Repeat on adjacent lock screws. Once all lock screws have been loosened, slide the rod-to-rod connector off the rod and lift up to remove.



ARMADA[™] SURGICAL TECHNIQUE

IMPLANT REMOVAL (CONT.)

Step 4: Screw Removal

Insert the tip of the appropriate Screwdriver (Poly/PLS/Uni, Fixed, Reduction, Closed Iliac) into the head of the screw and secure into position by threading the outer sleeve into the tulip. Remove the screw by rotating the Screwdriver handle counterclockwise. If preferred, the Screw Adjuster may be used by inserting into the shaft of the screw and turning counterclockwise to remove. To remove the provisional locking screw, insert the Fixed Screwdriver into the head of the screw and secure into position by threading the outer sleeve into the tulip. Rotate the Fixed Screwdriver counterclockwise in an orbital motion to remove.

Step 5: Hook Removal

Grasp the hook with an Implant Holder and slide in a cephalad or caudal direction to remove.



ARMADA[™] SYSTEM

ARMADA[™] 5.5mm DEGENERATIVE INSTRUMENT TRAY ONE

ARMADA 5.5mm DEGENERATIVE INSTRUMENT TRAY ONE



SCREWDRIVER



BALL TIP PEDICLE PROBE



BALL TIP PEDICLE PROBE, DUAL



DOUBLE LEAD TAP, 4.0mm



DOUBLE LEAD TAP, 4.5mm



DOUBLE LEAD TAP, 5.0mm



ARMADA[™] SYSTEM

ARMADA[™] 5.5mm DEGENERATIVE INSTRUMENT TRAY ONE

DOUBLE LEAD TAP, 5.5mm

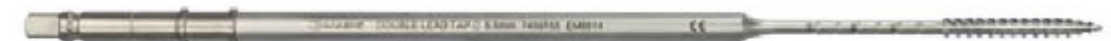

DOUBLE LEAD TAP, 6.5mm



DOUBLE LEAD TAP, 7.5mm



DOUBLE LEAD TAP, 8.5mm



AWL



NARROW AWL



ARMADA[™] SYSTEM

ARMADA[™] 5.5mm DEGENERATIVE INSTRUMENT TRAY ONE

NARROW GEARSHIFT PROBE, STRAIGHT



NARROW GEARSHIFT PROBE, CURVED



GEARSHIFT PROBE, CURVED



SELF-RETAINING SCREWDRIVER, 5.5mm ROD



LOCK SCREW STARTER, STRAIGHT



ARMADA[™] SYSTEM

ARMADA[™] 5.5mm DEGENERATIVE INSTRUMENT TRAY ONE

LOCK SCREW GUIDE/DEROTATION TOWER



SCREW ADJUSTER



SCREW HEAD ADJUSTER, 5.5mm ROD



LOCK SCREW STARTER



ARMADA[™] SYSTEM

ARMADA[™] 5.5mm DEGENERATIVE INSTRUMENT TRAY ONE



ARMADA[™] SYSTEM

ARMADA[™] 5.5mm DEGENERATIVE INSTRUMENT TRAY TWO

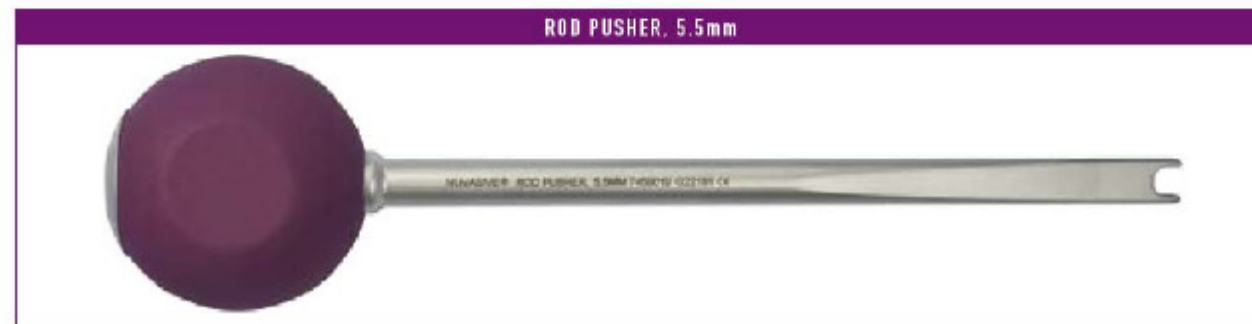

ARMADA[™] SYSTEM

ARMADA[™] SYSTEM

ARMADA[™] 5.5mm DEGENERATIVE INSTRUMENT TRAY TWO

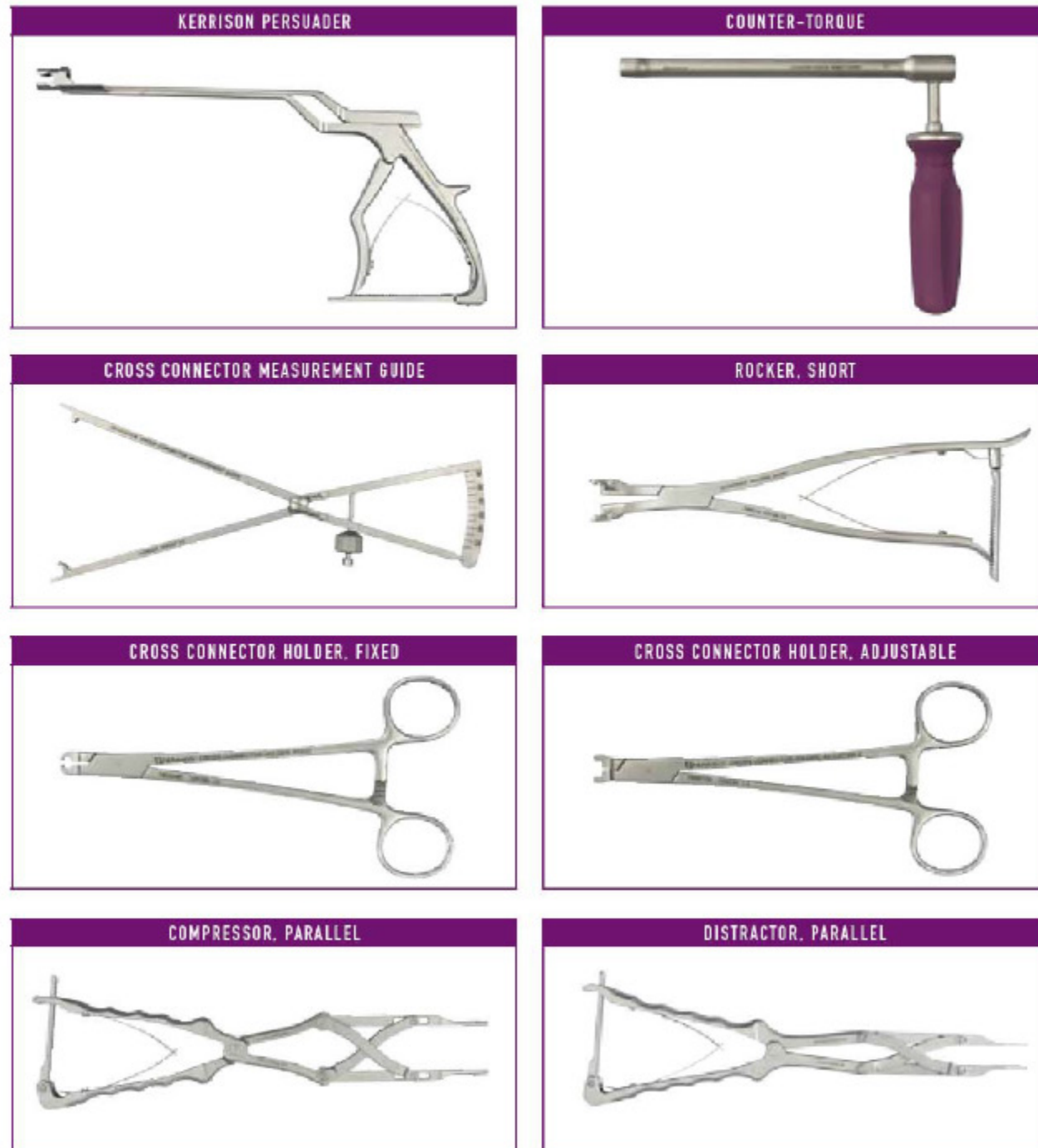

ARMADA[™] 5.5mm DEGENERATIVE INSTRUMENT TRAY TWO



ARMADA[™] SYSTEM

ARMADA[™] 5.5mm DEFORMITY INSTRUMENT TRAY ONE

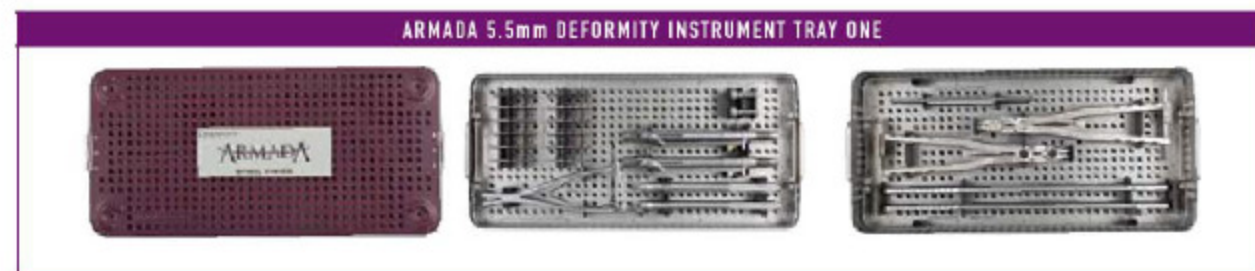

ARMADA[™] SYSTEM

ARMADA[™] 5.5mm DEFORMITY INSTRUMENT TRAY ONE



ARMADA[™] SYSTEM

ARMADA[™] 5.5mm DEFORMITY INSTRUMENT TRAY TWO



ARMADA[™] SYSTEM

ARMADA[™] ROD CUTTER TRAY



ARMADA[™] SYSTEM

ARMADA[™] 5.5mm TI DEGENERATIVE IMPLANT TRAY

ARMADA 5.5mm TI DEGENERATIVE IMPLANT TRAY

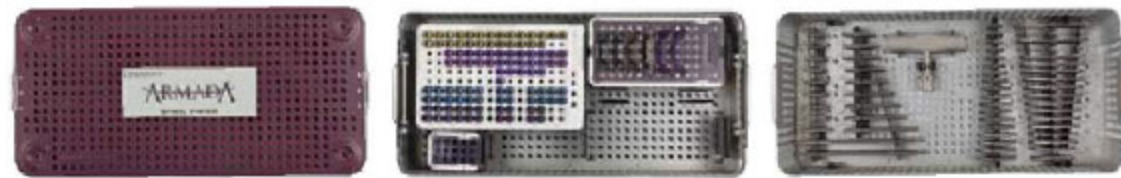

TORQUE T-HANDLE



ARMADA[™] SYSTEM

ARMADA[™] 5.5mm TI LONG CONSTRUCT IMPLANT TRAY

ARMADA 5.5mm TI LONG CONSTRUCT IMPLANT TRAY



ILIAC SCREWDRIVER, CLOSED



ILIAC PROBE



CLOSED ILIAC COUNTER-TORQUE



OPEN OFFSET CONNECTOR COUNTER-TORQUE



ROD TEMPLATE, 250mm



ARMADA[™] SYSTEM

ARMADA[™] 5.5mm TI LONG CONSTRUCT IMPLANT TRAY

ROD TEMPLATE, 500mm



DOUBLE LEAD TAP, 5.5mm



DOUBLE LEAD TAP, 6.5mm



DOUBLE LEAD TAP, 7.5mm



DOUBLE LEAD TAP, 8.5mm



ARMADA[™] SYSTEM

ARMADA[™] 5.5mm TI REDUCTION SCREW IMPLANT TRAY

ARMADA 5.5mm TI REDUCTION SCREW IMPLANT TRAY



REDUCTION SCREW BREAK-OFF TOOL



REDUCTION SCREWDRIVER



REDUCTION COUNTER-TORQUE



ARMADA[™] SYSTEM

ARMADA[™] 5.5mm TI OPEN ILIAC IMPLANT TRAY



ARMADA[™] SYSTEM

ARMADA[™] 5.5mm TI DEFORMITY IMPLANT TRAY ONE

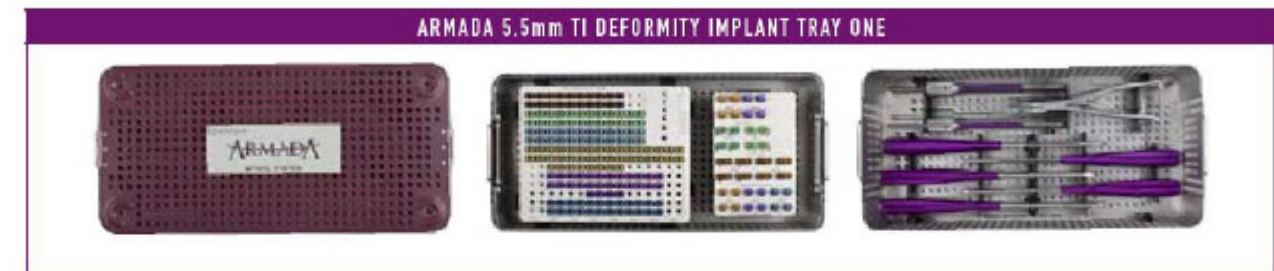

PEDICLE ELEVATOR



HOOK INSERTER



LAMINA ELEVATOR



HOOK PUSHER



TRANSVERSE PROCESS ELEVATOR



ARMADA[™] SYSTEM

ARMADA[™] 5.5mm TI DEFORMITY IMPLANT TRAY ONE



ARMADA[™] SYSTEM

ARMADA[™] 5.5mm TI DEFORMITY IMPLANT TRAY TWO



CATALOG

ARMADA™ TRAYS

DESCRIPTION	CATALOG #
5.5mm DEGENERATIVE INSTRUMENT TRAY ONE	
Awl	7451001
Narrow Awl	7451002
Narrow Gearshift Probe, Curved	7459004
Narrow Gearshift Probe, Straight	7459003
Gearshift Probe, Curved	7459006
Double Lead Tap, 4.0mm	7459140
Double Lead Tap, 4.5mm	7459145
Double Lead Tap, 5.0mm	7459150
Double Lead Tap, 5.5mm	7459155
Double Lead Tap, 6.5mm	7459165
Double Lead Tap, 7.5mm	7459175
Double Lead Tap, 8.5mm	7459185
Ball Tip Pedicle Probe	7459007
Ball Tip Pedicle Probe, Dual	7459008
Quick Connect Straight Handle	7240010
Quick Connect T-Handle	7240041
Self-Retaining Screwdriver, 5.5mm Rod	7459015
Screw Adjuster	7459016
Screw Head Adjuster, 5.5mm Rod	7459094
Screwdriver	7459014
French Bender	7459036
Lock Screw Guide/Derotation Tower	7459020
Lock Screw Starter	7459021
Lock Screw Starter, Straight	7459022
Rod Holder, 5.5mm Rod	7459024
5.5mm DEGENERATIVE INSTRUMENT TRAY TWO	
Reduction Tower	7459011
Reduction Tower T-Handle	7459012
Rocker, Short	7459112
Rod Pusher, 5.5mm Rod	7459019
Kerrison Persuader	7459009
Counter-Torque	7459017
Fixed Cross Connector Bender, Left	7451110
Fixed Cross Connector Bender, Right	7451111
Cross Connector Torque T-Handle	7240084
Fixed Cross Connector Driver	7459116
Lock Screw Driver	7459023
Adjustable Cross Connector Driver	7459115
Cross Connector Measurement Guide	7459045
Cross Connector Holder, Fixed	7459046
Cross Connector Holder, Adjustable	7459119

DESCRIPTION	CATALOG #
5.5mm DEGENERATIVE INSTRUMENT TRAY TWO (CONT.)	
Compressor, Parallel	7459041
Distractor, Parallel	7459043
Reduction Tower Counter-Torque	7459091
5.5mm DEFORMITY INSTRUMENT TRAY ONE	
Rocker, Long	7459010
Reduction Tower	7459011
Lock Screw Guide/Derotation Tower	7459020
Pedicle Marker, Spherical 40mm	7459120
Pedicle Marker, Diamond 40mm	7459121
Provisional Locking Tool	7459126
Rod Bender, Left	7459037
Rod Bender, Right	7459065
Rod Rotation Wrench	7459033
Rod Gripper, 5.5mm Rod	7459102
5.5mm DEFORMITY INSTRUMENT TRAY TWO	
In-Situ Sagittal Bender, 5.5mm Rod, Left	7459029
In-Situ Sagittal Bender, 5.5mm Rod, Right	7459030
In-Situ Coronal Bender, 5.5mm Rod, Left	7459031
In-Situ Coronal Bender, 5.5mm Rod, Right	7459032
Compressor	7451042
Distractor	7451044
ARMADA ROD CUTTER TRAY	
Tabletop Rod Cutter	7459039



CATALOG

ARMADA™ TRAYS

DESCRIPTION	CATALOG #
5.5mm TI DEGENERATIVE IMPLANT TRAY	
5.5mm x 30mm Polyaxial Screw, 5.5mm Ti	8455530
5.5mm x 35mm Polyaxial Screw, 5.5mm Ti	8455535
5.5mm x 40mm Polyaxial Screw, 5.5mm Ti	8455540
5.5mm x 45mm Polyaxial Screw, 5.5mm Ti	8455545
5.5mm x 50mm Polyaxial Screw, 5.5mm Ti	8455550
5.5mm x 55mm Polyaxial Screw, 5.5mm Ti	8455555
6.5mm x 35mm Polyaxial Screw, 5.5mm Ti	8456535
6.5mm x 40mm Polyaxial Screw, 5.5mm Ti	8456540
6.5mm x 45mm Polyaxial Screw, 5.5mm Ti	8456545
6.5mm x 50mm Polyaxial Screw, 5.5mm Ti	8456550
6.5mm x 55mm Polyaxial Screw, 5.5mm Ti	8456555
7.5mm x 30mm Polyaxial Screw, 5.5mm Ti	8457530
7.5mm x 35mm Polyaxial Screw, 5.5mm Ti	8457535
7.5mm x 40mm Polyaxial Screw, 5.5mm Ti	8457540
7.5mm x 45mm Polyaxial Screw, 5.5mm Ti	8457545
7.5mm x 50mm Polyaxial Screw, 5.5mm Ti	8457550
7.5mm x 55mm Polyaxial Screw, 5.5mm Ti	8457555
8.5mm x 30mm Polyaxial Screw, 5.5mm Ti	8458530
8.5mm x 35mm Polyaxial Screw, 5.5mm Ti	8458535
8.5mm x 40mm Polyaxial Screw, 5.5mm Ti	8458540
8.5mm x 45mm Polyaxial Screw, 5.5mm Ti	8458545
8.5mm x 50mm Polyaxial Screw, 5.5mm Ti	8458550
Lock Screw, Ti	8461100
Adjust. Trans Connector, 45-50mm	8450245
Adjust. Trans Connector, 50-60mm	8450250
Adjust. Trans Connector, 60-70mm	8450260
5.5mm Ti Rod, 25mm	8452025
5.5mm Ti Rod, 30mm	8452030
5.5mm Ti Rod, 35mm	8452035
5.5mm Ti Rod, 40mm	8452040
5.5mm Ti Rod, 45mm	8452045
5.5mm Ti Rod, 50mm	8452050
5.5mm Ti Rod, 55mm	8452055
5.5mm Ti Rod, 60mm	8452060
5.5mm Ti Rod, 65mm	8452065
5.5mm Ti Rod, 70mm	8452070
5.5mm Ti Rod, 80mm	8452080
5.5mm Ti Rod, 90mm	8452090
5.5mm Ti Rod, 100mm	8452100
5.5mm Ti Rod, 120mm	8452120
5.5mm Ti Rod, 200mm	8452200

DESCRIPTION	CATALOG #
5.5mm TI DEGENERATIVE IMPLANT TRAY (CONT.)	
5.5mm Pre-Bent Ti Rod, 25mm	8052025
5.5mm Pre-Bent Ti Rod, 30mm	8052030
5.5mm Pre-Bent Ti Rod, 35mm	8052035
5.5mm Pre-Bent Ti Rod, 40mm	8052040
5.5mm Pre-Bent Ti Rod, 45mm	8052045
5.5mm Pre-Bent Ti Rod, 50mm	8052050
5.5mm Pre-Bent Ti Rod, 55mm	8052055
5.5mm Pre-Bent Ti Rod, 60mm	8052060
5.5mm Pre-Bent Ti Rod, 65mm	8052065
5.5mm Pre-Bent Ti Rod, 70mm	8052070
5.5mm Pre-Bent Ti Rod, 75mm	8052075
5.5mm Pre-Bent Ti Rod, 80mm	8052080
5.5mm Pre-Bent Ti Rod, 85mm	8052085
5.5mm Pre-Bent Ti Rod, 90mm	8052090
5.5mm Pre-Bent Ti Rod, 95mm	8052095
5.5mm Pre-Bent Ti Rod, 100mm	8052100
5.5mm Pre-Bent Ti Rod, 110mm	8052110
5.5mm Pre-Bent Ti Rod, 120mm	8052120
Torque T-Handle	7240025



CATALOG

ARMADA™ TRAYS

DESCRIPTION	CATALOG #
5.5mm TI LONG CONSTRUCT IMPLANT TRAY	
4.0mm x 25mm Polyaxial Screw, 5.5mm Ti	8454025
4.0mm x 30mm Polyaxial Screw, 5.5mm Ti	8454030
4.0mm x 35mm Polyaxial Screw, 5.5mm Ti	8454035
4.0mm x 40mm Polyaxial Screw, 5.5mm Ti	8454040
4.0mm x 45mm Polyaxial Screw, 5.5mm Ti	8454045
4.5mm x 25mm Polyaxial Screw, 5.5mm Ti	8454525
4.5mm x 30mm Polyaxial Screw, 5.5mm Ti	8454530
4.5mm x 35mm Polyaxial Screw, 5.5mm Ti	8454535
4.5mm x 40mm Polyaxial Screw, 5.5mm Ti	8454540
4.5mm x 45mm Polyaxial Screw, 5.5mm Ti	8454545
5.0mm x 25mm Polyaxial Screw, 5.5mm Ti	8455025
5.0mm x 30mm Polyaxial Screw, 5.5mm Ti	8455030
5.0mm x 35mm Polyaxial Screw, 5.5mm Ti	8455035
5.0mm x 40mm Polyaxial Screw, 5.5mm Ti	8455040
5.0mm x 45mm Polyaxial Screw, 5.5mm Ti	8455045
5.0mm x 50mm Polyaxial Screw, 5.5mm Ti	8455050
5.5mm x 25mm Polyaxial Screw, 5.5mm Ti	8455525
5.5mm x 30mm Polyaxial Screw, 5.5mm Ti	8455530
5.5mm x 35mm Polyaxial Screw, 5.5mm Ti	8455535
5.5mm x 40mm Polyaxial Screw, 5.5mm Ti	8455540
5.5mm x 45mm Polyaxial Screw, 5.5mm Ti	8455545
5.5mm x 50mm Polyaxial Screw, 5.5mm Ti	8455550
5.5mm x 55mm Polyaxial Screw, 5.5mm Ti	8455555
6.5mm x 30mm Polyaxial Screw, 5.5mm Ti	8456530
6.5mm x 35mm Polyaxial Screw, 5.5mm Ti	8456535
6.5mm x 40mm Polyaxial Screw, 5.5mm Ti	8456540
6.5mm x 45mm Polyaxial Screw, 5.5mm Ti	8456545
6.5mm x 50mm Polyaxial Screw, 5.5mm Ti	8456550
6.5mm x 55mm Polyaxial Screw, 5.5mm Ti	8456555
6.5mm x 60mm Polyaxial Screw, 5.5mm Ti	8456560
6.5mm x 60mm Iliac Screw, Single Lead Closed, 5.5mm Ti	8436560
6.5mm x 70mm Iliac Screw, Single Lead Closed, 5.5mm Ti	8436570
6.5mm x 80mm Iliac Screw, Single Lead Closed, 5.5mm Ti	8436580
6.5mm x 90mm Iliac Screw, Single Lead Closed, 5.5mm Ti	8436590
6.5mm x 100mm Iliac Screw, Single Lead Closed, 5.5mm Ti	8436510
7.5mm x 60mm Iliac Screw, Single Lead Closed, 5.5mm Ti	8437560
7.5mm x 70mm Iliac Screw, Single Lead Closed, 5.5mm Ti	8437570
7.5mm x 80mm Iliac Screw, Single Lead Closed, 5.5mm Ti	8437580
7.5mm x 90mm Iliac Screw, Single Lead Closed, 5.5mm Ti	8437590
7.5mm x 100mm Iliac Screw, Single Lead Closed, 5.5mm Ti	8437510

DESCRIPTION	CATALOG #
5.5mm TI LONG CONSTRUCT IMPLANT TRAY (CONT.)	
8.5mm x 60mm Iliac Screw, Single Lead Closed, 5.5mm Ti	8438560
8.5mm x 70mm Iliac Screw, Single Lead Closed, 5.5mm Ti	8438570
8.5mm x 80mm Iliac Screw, Single Lead Closed, 5.5mm Ti	8438580
8.5mm x 90mm Iliac Screw, Single Lead Closed, 5.5mm Ti	8438590
8.5mm x 100mm Iliac Screw, Single Lead Closed, 5.5mm Ti	8438510
9.5mm x 60mm Iliac Screw, Single Lead Closed, 5.5mm Ti	8439560
9.5mm x 70mm Iliac Screw, Single Lead Closed, 5.5mm Ti	8439570
9.5mm x 80mm Iliac Screw, Single Lead Closed, 5.5mm Ti	8439580
9.5mm x 90mm Iliac Screw, Single Lead Closed, 5.5mm Ti	8439590
9.5mm x 100mm Iliac Screw, Single Lead Closed, 5.5mm Ti	8439510
Lock Screw, Ti	8461100
Closed Tulip Lock Screw, Ti	8051100
Single Lead Tap, 5.5mm	7459255
Single Lead Tap, 6.5mm	7459265
Single Lead Tap, 7.5mm	7459275
Single Lead Tap, 8.5mm	7459285
Iliac Probe	7451090
Iliac Screwdriver, Closed	7459107
Closed Iliac Counter-Torque	7459114
Open Offset Connector Counter-Torque	7459118
20mm Fixed Cross Connector, 5.5mm Ti	8450120
Fixed Cross Connector, 22.5mm, 5.5mm Ti	8450122
Fixed Cross Connector, 25mm, 5.5mm Ti	8450125
Fixed Cross Connector, 27.5mm, 5.5mm Ti	8450127
Fixed Cross Connector, 30mm, 5.5mm Ti	8450130
Fixed Cross Connector, 32.5mm, 5.5mm Ti	8450132
Fixed Cross Connector, 35mm, 5.5mm Ti	8450135
Fixed Cross Connector, 37.5mm, 5.5mm Ti	8450137
Fixed Cross Connector, 40mm, 5.5mm Ti	8450140
Fixed Cross Connector, 45mm, 5.5mm Ti	8450145
Fixed Cross Connector, 50mm, 5.5mm Ti	8450150
Fixed Cross Connector, 55mm, 5.5mm Ti	8450155
Fixed Cross Connector, 60mm, 5.5mm Ti	8450160
Open Offset Connector, 20mm, 5.5mm Ti	8650520
Open Offset Connector, 30mm, 5.5mm Ti	8650530
Open Offset Connector, 60mm, 5.5mm Ti	8650560



CATALOG

ARMADA™ TRAYS

DESCRIPTION	CATALOG #
5.5mm TI LONG CONSTRUCT IMPLANT TRAY (CONT.)	
In-Line Rod Connector, 5.5/5.5mm Ti	8451302
In-Line Rod Connector, 6.25/5.5mm Ti	8461302
Parallel Rod Connector, 5.5/5.5mm Ti	8451402
Parallel Rod Connector, 6.25/5.5mm Ti	8461402
4-Hole Rod Connector, 5.5/5.5mm Ti	8451602
4-Hole Rod Connector, 6.25/5.5mm Ti	8461602
5.5mm Ti Rod, 300mm	8452300
5.5mm Ti Rod, 500mm	8452500
5.5mm CoCr Rod, 300mm	8252300
5.5mm CoCr Rod, 500mm	8252500
Rod Template, 250mm	7240033
Rod Template, 500mm	7240034

DESCRIPTION	CATALOG #
5.5mm TI REDUCTION SCREW IMPLANT TRAY	
Reduction Counter-Torque	7459105
Reduction Screwdriver	7459104
Reduction Screw Break-Off Tool	7459013
5.5mm x 30mm Reduction Screw, 5.5mm Ti	8275530
5.5mm x 35mm Reduction Screw, 5.5mm Ti	8275535
5.5mm x 40mm Reduction Screw, 5.5mm Ti	8275540
5.5mm x 45mm Reduction Screw, 5.5mm Ti	8275545
5.5mm x 50mm Reduction Screw, 5.5mm Ti	8275550
5.5mm x 55mm Reduction Screw, 5.5mm Ti	8275555
6.5mm x 30mm Reduction Screw, 5.5mm Ti	8276530
6.5mm x 35mm Reduction Screw, 5.5mm Ti	8276535
6.5mm x 40mm Reduction Screw, 5.5mm Ti	8276540
6.5mm x 45mm Reduction Screw, 5.5mm Ti	8276545
6.5mm x 50mm Reduction Screw, 5.5mm Ti	8276550
6.5mm x 55mm Reduction Screw, 5.5mm Ti	8276555
7.5mm x 30mm Reduction Screw, 5.5mm Ti	8277530
7.5mm x 35mm Reduction Screw, 5.5mm Ti	8277535
7.5mm x 40mm Reduction Screw, 5.5mm Ti	8277540
7.5mm x 45mm Reduction Screw, 5.5mm Ti	8277545
7.5mm x 50mm Reduction Screw, 5.5mm Ti	8277550
7.5mm x 55mm Reduction Screw, 5.5mm Ti	8277555



CATALOG

ARMADA[™] TRAYS

DESCRIPTION	CATALOG #
5.5mm TI OPEN ILIAC IMPLANT TRAY	
6.5mm x 60mm Iliac Screw, Single Lead Open, 5.5mm Ti	8446560
6.5mm x 70mm Iliac Screw, Single Lead Open, 5.5mm Ti	8446570
6.5mm x 80mm Iliac Screw, Single Lead Open, 5.5mm Ti	8446580
6.5mm x 90mm Iliac Screw, Single Lead Open, 5.5mm Ti	8446590
6.5mm x 100mm Iliac Screw, Single Lead Open, 5.5mm Ti	8446510
7.5mm x 60mm Iliac Screw, Single Lead Open, 5.5mm Ti	8447560
7.5mm x 70mm Iliac Screw, Single Lead Open, 5.5mm Ti	8447570
7.5mm x 80mm Iliac Screw, Single Lead Open, 5.5mm Ti	8447580
7.5mm x 90mm Iliac Screw, Single Lead Open, 5.5mm Ti	8447590
7.5mm x 100mm Iliac Screw, Single Lead Open, 5.5mm Ti	8447510
8.5mm x 60mm Iliac Screw, Single Lead Open, 5.5mm Ti	8448560
8.5mm x 70mm Iliac Screw, Single Lead Open, 5.5mm Ti	8448570
8.5mm x 80mm Iliac Screw, Single Lead Open, 5.5mm Ti	8448580
8.5mm x 90mm Iliac Screw, Single Lead Open, 5.5mm Ti	8448590
8.5mm x 100mm Iliac Screw, Single Lead Open, 5.5mm Ti	8448510
9.5mm x 60mm Iliac Screw, Single Lead Open, 5.5mm Ti	8449560
9.5mm x 70mm Iliac Screw, Single Lead Open, 5.5mm Ti	8449570
9.5mm x 80mm Iliac Screw, Single Lead Open, 5.5mm Ti	8449580
9.5mm x 90mm Iliac Screw, Single Lead Open, 5.5mm Ti	8449590
9.5mm x 100mm Iliac Screw, Single Lead Open, 5.5mm Ti	8449510
Closed Tulip Lock Screw, Ti	8051100
Closed Offset Connector, 20mm, 5.5mm Ti	8651520
Closed Offset Connector, 30mm, 5.5mm Ti	8651530
Closed Offset Connector, 60mm, 5.5mm Ti	8651560
5.5mm TI DEFORMITY IMPLANT TRAY ONE	
4.0mm x 25mm Fixed Screw, 5.5mm Ti	8854025
4.0mm x 30mm Fixed Screw, 5.5mm Ti	8854030
4.0mm x 35mm Fixed Screw, 5.5mm Ti	8854035
4.0mm x 40mm Fixed Screw, 5.5mm Ti	8854040
4.0mm x 45mm Fixed Screw, 5.5mm Ti	8854045
4.5mm x 25mm Fixed Screw, 5.5mm Ti	8854525
4.5mm x 30mm Fixed Screw, 5.5mm Ti	8854530
4.5mm x 35mm Fixed Screw, 5.5mm Ti	8854535
4.5mm x 40mm Fixed Screw, 5.5mm Ti	8854540
4.5mm x 45mm Fixed Screw, 5.5mm Ti	8854545
4.5mm x 50mm Fixed Screw, 5.5mm Ti	8854550
5.0mm x 25mm Fixed Screw, 5.5mm Ti	8855025
5.0mm x 30mm Fixed Screw, 5.5mm Ti	8855030
5.0mm x 35mm Fixed Screw, 5.5mm Ti	8855035
5.0mm x 40mm Fixed Screw, 5.5mm Ti	8855040
5.0mm x 45mm Fixed Screw, 5.5mm Ti	8855045
5.0mm x 50mm Fixed Screw, 5.5mm Ti	8855050

DESCRIPTION	CATALOG #
5.5mm TI DEFORMITY IMPLANT TRAY ONE (CONT.)	
5.5mm x 25mm Fixed Screw, 5.5mm Ti	8855525
5.5mm x 30mm Fixed Screw, 5.5mm Ti	8855530
5.5mm x 35mm Fixed Screw, 5.5mm Ti	8855535
5.5mm x 40mm Fixed Screw, 5.5mm Ti	8855540
5.5mm x 45mm Fixed Screw, 5.5mm Ti	8855545
5.5mm x 50mm Fixed Screw, 5.5mm Ti	8855550
5.5mm x 55mm Fixed Screw, 5.5mm Ti	8855555
5.5mm x 60mm Fixed Screw, 5.5mm Ti	8855560
6.5mm x 30mm Fixed Screw, 5.5mm Ti	8856530
6.5mm x 35mm Fixed Screw, 5.5mm Ti	8856535
6.5mm x 40mm Fixed Screw, 5.5mm Ti	8856540
6.5mm x 45mm Fixed Screw, 5.5mm Ti	8856545
6.5mm x 50mm Fixed Screw, 5.5mm Ti	8856550
6.5mm x 55mm Fixed Screw, 5.5mm Ti	8856555
7.5mm x 30mm Fixed Screw, 5.5mm Ti	8857530
7.5mm x 35mm Fixed Screw, 5.5mm Ti	8857535
7.5mm x 40mm Fixed Screw, 5.5mm Ti	8857540
7.5mm x 45mm Fixed Screw, 5.5mm Ti	8857545
7.5mm x 50mm Fixed Screw, 5.5mm Ti	8857550
7.5mm x 55mm Fixed Screw, 5.5mm Ti	8857555
Pedicle Hook, Small, 5.5mm Ti	8453101
Pedicle Hook, Medium, 5.5mm Ti	8453102
Lamina Hook Reduced W, 6mm, 5.5mm Ti	8453112
Lamina Hook Reduced W, 8mm, 5.5mm Ti	8453113
Lamina Hook Reduced W, 10mm, 5.5mm Ti	8453114
Angled Hook, Right, 5.5mm Ti	8453121
Angled Hook, Left, 5.5mm Ti	8453122
Offset Hook, Right, 5.5mm Ti	8453123
Offset Hook, Left, 5.5mm Ti	8453124
Fixed Screwdriver, 5.5mm Rod	7459088
Implant Holder	7459040
Pedicle Elevator	7459055
Hook Inserter	7459056
Lamina Elevator	7459057
Hook Pusher	7459058
Transverse Process Elevator	7459059



CATALOG

ARMADA[™] TRAYS

DESCRIPTION	CATALOG #
5.5mm TI DEFORMITY IMPLANT TRAY TWO	
4.0mm x 25mm Provisional Locking Screw, 5.5mm Ti	8254025
4.0mm x 30mm Provisional Locking Screw, 5.5mm Ti	8254030
4.0mm x 35mm Provisional Locking Screw, 5.5mm Ti	8254035
4.0mm x 40mm Provisional Locking Screw, 5.5mm Ti	8254040
4.0mm x 45mm Provisional Locking Screw, 5.5mm Ti	8254045
4.5mm x 25mm Provisional Locking Screw, 5.5mm Ti	8254525
4.5mm x 30mm Provisional Locking Screw, 5.5mm Ti	8254530
4.5mm x 35mm Provisional Locking Screw, 5.5mm Ti	8254535
4.5mm x 40mm Provisional Locking Screw, 5.5mm Ti	8254540
4.5mm x 45mm Provisional Locking Screw, 5.5mm Ti	8254545
5.0mm x 25mm Provisional Locking Screw, 5.5mm Ti	8255025
5.0mm x 30mm Provisional Locking Screw, 5.5mm Ti	8255030
5.0mm x 35mm Provisional Locking Screw, 5.5mm Ti	8255035
5.0mm x 40mm Provisional Locking Screw, 5.5mm Ti	8255040
5.0mm x 45mm Provisional Locking Screw, 5.5mm Ti	8255045
5.0mm x 50mm Provisional Locking Screw, 5.5mm Ti	8255050
5.5mm x 25mm Provisional Locking Screw, 5.5mm Ti	8255525
5.5mm x 30mm Provisional Locking Screw, 5.5mm Ti	8255530
5.5mm x 35mm Provisional Locking Screw, 5.5mm Ti	8255535
5.5mm x 40mm Provisional Locking Screw, 5.5mm Ti	8255540
5.5mm x 45mm Provisional Locking Screw, 5.5mm Ti	8255545
5.5mm x 50mm Provisional Locking Screw, 5.5mm Ti	8255550
5.5mm x 55mm Provisional Locking Screw, 5.5mm Ti	8255555
6.5mm x 30mm Provisional Locking Screw, 5.5mm Ti	8256530
6.5mm x 35mm Provisional Locking Screw, 5.5mm Ti	8256535
6.5mm x 40mm Provisional Locking Screw, 5.5mm Ti	8256540
6.5mm x 45mm Provisional Locking Screw, 5.5mm Ti	8256545
6.5mm x 50mm Provisional Locking Screw, 5.5mm Ti	8256550
6.5mm x 55mm Provisional Locking Screw, 5.5mm Ti	8256555
Screwdriver	7459014





To order, please contact your NuVasive® Sales Consultant or Customer Service Representative today at:
7475 Lusk Blvd., San Diego, CA 92121 • phone: 800-475-9131 fax: 800-475-9134

www.nuvasive.com

9500480 A.0